

# Intelligent Control of Maximum Power Point Tracking (MPPT) of Grid-Connected Photovoltaic Installations

**David Ricardo Macas-Mendoza<sup>1</sup>**

**Ismael Elías Erazo-Velasco<sup>2</sup>**

**Junior Manfredo Rojas-Rosado<sup>3</sup>**

**José Vicencio Bautista-Sánchez<sup>4</sup>**

**Byron Emilio Blandon-Matamba<sup>5</sup>**

**Roberto Iván Rodríguez-Jijón<sup>6</sup>**

1. david.macas.mendoza@utelvt.edu.ec  
<https://orcid.org/0000-0003-2913-5956>  
Universidad Técnica Luis Vargas Torres de Esmeraldas-Ecuador
2. ismael.erazo@utelvt.edu.ec  
<https://orcid.org/0000-0002-7647-4611>  
Universidad Técnica Luis Vargas Torres de Esmeraldas-Ecuador
3. junior.rojas.rosado@utelvt.edu.ec  
<https://orcid.org/0000-0003-0037-4283>  
Universidad Técnica Luis Vargas Torres de Esmeraldas-Ecuador
4. jose.bautista@utelvt.edu.ec  
<https://orcid.org/0000-0003-3358-1908>  
Universidad Técnica Luis Vargas Torres de Esmeraldas-Ecuador
5. byron.blandon.matamba@utelvt.edu.ec  
<https://orcid.org/0009-0001-8419-0491>  
Universidad Técnica Luis Vargas Torres de Esmeraldas-Ecuador
6. roberto.rodriguez@utelvt.edu.ec  
<https://orcid.org/0000-0003-1055-7921>  
Universidad Técnica Luis Vargas Torres de Esmeraldas-Ecuador

## ABSTRACT

The objective of the research was to determine within the intelligent control algorithms for monitoring the Maximum Power Point, which is the most efficient for photovoltaic installations connected to the network. The technical and descriptive methodology planned the design of the microgrid. In addition, the simulation was proposed using the MATLAB/Simulink software, an intelligent control algorithm, based on Fuzzy logic for monitoring the maximum power point. The electric microgrid model and its energy management in the case study, proposes an area made up of 25 houses that is located in a climatic zone that provides ideal conditions. For reasons of availability of a renewable energy resource, photovoltaic energy is considered as a source of energy supply. In the design of the fuzzy controller, the inputs and outputs of the system were analyzed, variables were established, the respective universe of discourse and membership functions were proposed, so that they were better adjusted to the maximum power algorithm. The variables were defined, where the characteristic curves P vs V and I vs V of the solar modules were taken as reference, being the inputs to control the error (E) and the error variation (CE), and the output of the fuzzy controller (D) is the converter control signal, the same one that suffered increases and decreases to regulate that the system works at its maximum power point.

**Keywords:** Control Algorithm, Smart Technology, Photovoltaic Installations.

## Introduction

Today's society is constantly taking actions that set the tone in terms of environmental protection to mitigate the threat posed by climate change, based on this on a global scale, various agreements, conventions and treaties have been made to manage the environmental alterations produced by anthropogenic pollution. among which the 2030 Agenda for Sustainable Development should be highlighted.

In the case of the energy context, responsible nations and companies are obliged to seek behavior based on the principles of sustainability, given that according to experts from the United Nations Environment Program (UNEP), energy production is the factor that contributes most to climate change. It is there, then, where it is necessary to establish correctives, measures or models that allow this important economic sector to have the possibility of

managing the energy resource well under the premise that as a human right it must be accessible to the entire population, in addition to offering increasingly less polluting services for the environment.

Thus, the energy transition from non-renewable energy sources such as fossil fuels to renewable, non-polluting energy sources such as solar, wind or other energy is already a reality that several countries around the world, including Ecuador, are already traveling, taking into account that economic development measures are increasingly demanding from the perspective of environmental responsibility and in the idea of achieving the objectives of environmental responsibility together. Sustainable development (SDG) of the 2030 Agenda, which is set out in SDG number 7: Ensure access to affordable, safe, sustainable and modern energy. In order to channel energy processes on the basis of sustainable behaviour, technology has been a fundamental aspect that has allowed the development of tools that make the use of natural sources possible, such as photovoltaic solar energy, which allows solar panels to be integrated into different products, such as for the intelligent control of the maximum power point (MPPT) monitoring of photovoltaic installations connected to the grid. since its performance is to guarantee that the energy requirements of the load can be supplied.

Ecuador obtains a large part of its electrical energy from mostly hydroelectric power plants and thermoelectric generation plants, the latter producing CO<sub>2</sub> into the environment. Currently, in the process of energy transition that the Ecuadorian State has assumed for several years, it has eventually incorporated renewable energies as photovoltaic energy, however, it is necessary to expand its use further, because, due to its geographical location, the country has characteristics of high solar energy potential that can be classified as excellent for use as an alternative energy source according to international standards and make feasible The generation of electricity through photovoltaic energy in various regions where this fundamental basic service is still lacking or in the best of cases requires improvements to optimize the energy supply to the population.

In response to these indications, especially in Ecuador, the energy transition has been promoted for several years, within the framework of the guiding principles on environmental care and in the recognition, as stated by the governing body in Ecuadorian energy policy, the Ministry of Energy and Non-Renewable Natural Resources (MERNNR), of the need to build desirable national energy scenarios based on innovative methodologies and international experiences. contemplating the reality and self-determination in the sustainable development of the country (MERNN, 2019).

In addition, this institution states that the work of energy policies in Ecuadorian territory certainly aims at the purpose of adequately supplying the country's ever-growing demand for electricity, complying with criteria of reliability, quality, economy, and less environmental impact (MERNN, 2019).

In this sense, Ecuador has important natural resources with high possibilities that can be used as renewable energy sources, within which solar resources have been identified as having viable technical potential (MERNN, 2019). Thus, the characteristics of Ecuador's geographical location are ideal for embarking on activities related to optimizing energy access while addressing the risk of adverse impacts on the environment.

Some of the currently identified values of solar potential are presented in the Solar Atlas of Ecuador, a document issued by the National Electricity Council (CONELEC), in this way the average direct insolation value of continental Ecuador is 2,543 Wh/m<sup>2</sup>/day; the average diffuse insolation is 2,032 Wh/m<sup>2</sup>/day; and the average global insolation is 4,575 Wh/m<sup>2</sup>/day (CONELEC, 2008).

On this basis, at the national level, solar radiation is an excellent means to generate complementary energy to that from oil, because of this, the scenario that occurs in the Tachina Parish of the Esmeraldas canton in Ecuador, indicates that plans can be addressed related to the use of the solar energy source through photovoltaic technology to improve access to energy resources for the inhabitants under the focus of economic sustainability. social and environmental.

On this point, it is especially pertinent to highlight that in technological matters there has been a great expansion in information and communication technologies to innovate electrical systems that are increasingly pressured to meet the growing demand from the perspective of a quality, efficient, timely service, accessible to all people and with greater respect for the environment. In this idea, Guido & Carrizo (2016) highlights, technological innovations are key to deploying a new spectrum of supply possibilities with greater efficiency, in addition to introducing a new way of managing electricity flows.

In this sense, the objective of this work is to determine within the intelligent control algorithms for the monitoring of the maximum power point, which is the most efficient for the photovoltaic installations connected to the grid in the Tachina parish of the Esmeraldas canton, in order to provide answers and/or solutions to the difficulties encountered to optimize the electrical service in this locality.

### **Methodology**

This research is identified as a technical study, of descriptive level. In addition, it is supported by documentary and bibliographic research in order to theoretically support the study and the proposal. In considerations of Corral, &

Maldonado, (2011) a technical research complies with the cycle of Planning, Production and Function, based on the experience of the researcher to solve the research study problem. In this particular case, it offers a possible response or solution to a problematic situation found in the context of the parish of Tachina in the canton of Esmeraldas. Regarding descriptive research, Sabino (2000) refers to the fact that it is a matter of describing some significant characteristics of the reality addressed, which reveals relevant systematic information on the behavior of the phenomenon and comparable to that of other theoretical sources. It is also important to indicate that this work was supported by documentary research based on the consultation of several texts on the subject to support the interpretation of the reality investigated. According to Arias, (2004), documentary research is a process based on the search for information in secondary printed, electronic or audiovisual sources, for subsequent analysis and interpretation. In the same way, a simulation procedure was applied for the conceptual design of the selected technology, using the MATLAB/Simulink software, an intelligent control algorithm, based on Fuzzy Logic for the monitoring of the maximum power point in the parish of Tachina in the canton of Esmeraldas.

### Characterization of the study area

The Parish of Tachina is located in the North of the Republic of Ecuador, northeast of the canton and province of Esmeraldas, to the right of the city of Esmeraldas, on the right bank downstream of the Esmeraldas River, next to the mouth of the Esmeraldas River, separated by this wide and beautiful river, a privileged site for exploitation and ecotourism.

Figure 1. Location of Tachina Parish



Note. Location of the area where the project was carried out. Taken from *Google Maps*.

### Electricity demand

This project proposes as a case study, an area of the Tachina parish of the Esmeraldas Canton, which comprises 25 homes with an energy demand of around 25 KVA, in which it is intended to implement a photovoltaic microgrid that supplies energy to this area, it should be noted that the power factor of the system is 0.98.

Data:

$$S = 25 \text{ KVA}$$

$$F_p = 0,98$$

$$P = S * F_p = 25 * 0,98 = 24,5 \text{ KW}$$

Starting from the power, we will proceed to calculate the number of solar panels necessary to generate that amount of energy, in the following formula we will find:

$$\#N = \frac{E_r * 1,3}{H_p W_p}$$

Where:

#N: number of solar panels.

Er: Electricity demand

Hp: Peak operating hours of the photovoltaic microgrid 5 hours

Wp: The amount of power in KW that a solar panel can deliver, which depends on the manufacturer in this case, will be 0.34 KW.

$$\#N = \frac{24,5 \text{ KW} * 1,3}{5 * 0,34} = 18,7 \text{ :: } 18 \text{ Paneles fotovoltaicos}$$

### Solar array features

The maximum power point of a solar panel varies according to changes in solar irradiation and temperature. The typical characteristic curves of current versus voltage, power versus voltage at different levels of solar irradiation, and power versus voltage at different temperatures, are illustrated in Figure 2a and 2b respectively.

Figure 2. Voltage-Current and P-V characteristics of a solar cell for various temperature values

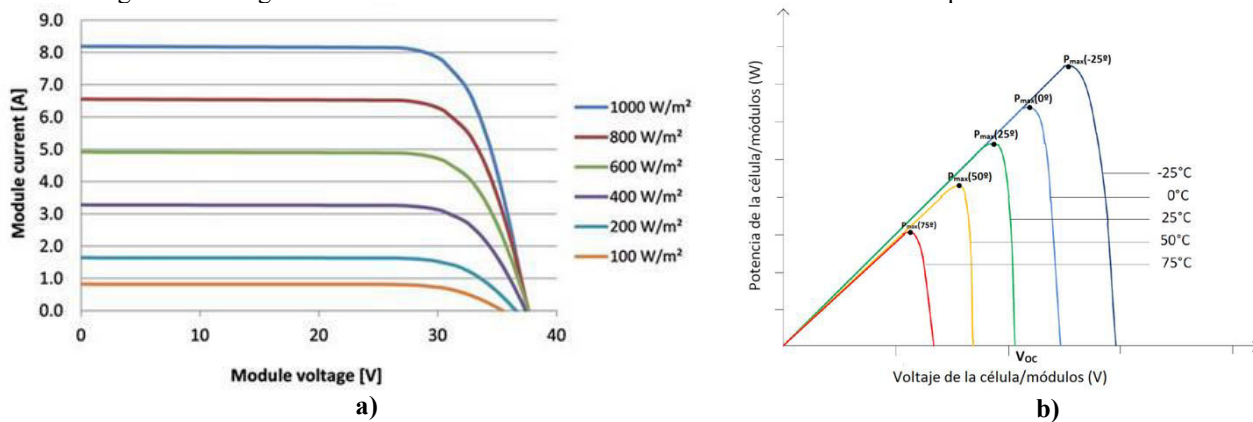

Note. Voltage-current curve for a solar cell with variation in solar irradiation. Taken from Granda (2017).

Note. Power-voltage curve for a solar cell with temperature variation. Taken from Granda (2017).

The region of the current source, in which the internal impedance of the panel is high, is located on the left side of the current-voltage curve. The MPPT of the panel is located at the knee of the current-voltage curve. According to the theory of maximum power transfer, the power delivered to the load is maximum when the internal impedance of the source matches the impedance of the load.

Therefore, the impedance seen from the input side of the converter (can be adjusted by PWM control signal) must match the internal impedance of the panel if the system is required to operate at or near the MPPT of the solar panel. If the system operates in the voltage source (low impedance) region of the panel's characteristic curve, the panel's terminal voltage will collapse.

From Figures 2a and 2b it can be seen that each curve has a maximum power point (MPP), which is the optimal point for the efficient use of the panel and this point depends on the temperature values. The primary function of an MPPT is to adjust the panel's output voltage to a value where the panel supplies maximum power to the load (Ravindran, Sutaria, 2016).

### Maximum Power Point MPPT

When a PV module is connected directly to a load, the PV module's operating point will be at the intersection of its I-V characteristic and the load line which is the I-V ratio of the load (Bandri, Syofian, & Effendi, 2019).

In general, this point of operation is not in the MPP of the photovoltaic field, which can be clearly seen in Figure 3.

Figure 3. V-I Curves with Various Resistive Loads

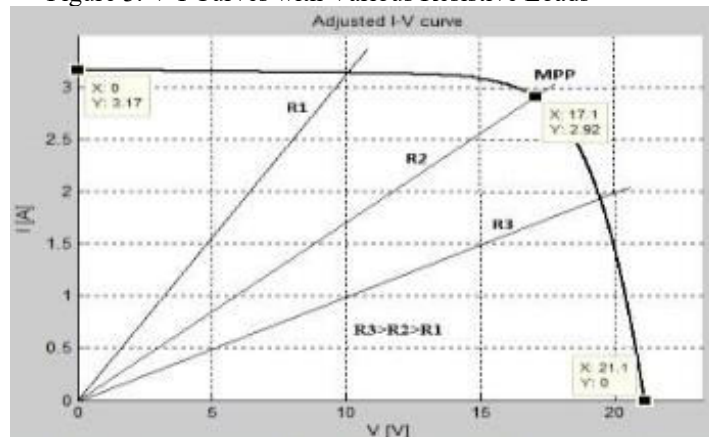

Note. Operating point of the PV module at the intersection of its I-V feature. Taken from Yatimi and Aroudam (2015).

Therefore, in a direct-coupled system, the PV array typically needs to be oversized to ensure that the power requirements of the load can be supplied. This leads to an overpriced system. To overcome this problem, a switched-mode power converter can be used to maintain the PV operating point in the MPPT.

The MPPT controls the voltage or current of the PV array independently of those of the load. However, the location of the MPPT in the I-V feature is not known a priori. It must be located, either through model calculation or by search algorithm. The situation is further complicated by the fact that MPPT is non-linearly dependent on irradiance and temperature (Yatimi & Aroudam, 2015).

### Solar Cell Output Features

The output power of the solar cell is a nonlinear function against the temperature and intensity of light, Figure 4 shows the relationship curve between the temperature and the output power of the solar cell, where the match between the solar panel and the battery bank or utility grid is optimized, and converts a high DC voltage to a low voltage needed to charge the batteries (Qin & Lu, 2012).

Figure 4. The Relationship Between Temperature and Power Output

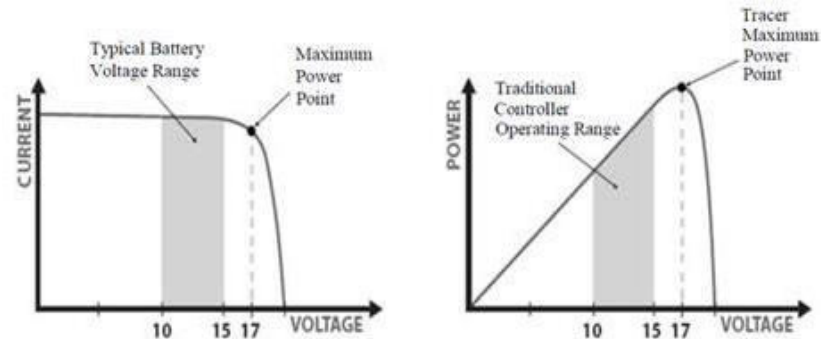

*Note.* Curve of the relationship between the temperature and the output power of the solar cell. Taken from (Qin and Lu, 2012).

### Maximum Power Point (MPPT) Tracking

It is a method of determining the point at which the maximum power generated by solar panels is produced. Based on research conducted by Prinanda and Sulistyowati, (2015), one of the advantages of using MPPT is the speed in satisfying the photovoltaic equilibrium condition for the conditions required by the load and that it can be filled with solar panels. MPPT requires two components that support the input current to operate. The two components are combined to obtain the power value  $P$  as in Equation 2.

$$P = V \times I \quad (1)$$

Under conditions of different temperature and irradiance, the values obtained from the MPPT are different. The proper method is required to obtain the value of the maximum power generated by the solar panels.

### Perturba y Observa Method

The Perturba y Observa method consists of two phases:

1. Change to disturb, send a voltage, or a current reference solar cell.
2. Observe, perform the power calculation caused by disturbing it.

The power benchmarking before and after the process disturbance performed as a reference used to increase or decrease the voltage to the next step and obtain the MPP value. In the research carried out by Francis et al (2012), algorithms were used and began by measuring the voltage  $V(k)$  and the current  $I(k)$  to obtain  $P(k)$  (Morales, 2010). Perturb ( $V$ ) given to observe the value of the output power  $P(k+1)$ .

The value of  $P(k+1)$  and then compared to your  $P(k)$ . If the value of  $P(k+1)$  is greater than  $P(k)$ , it can be concluded that the disturbance made by Niali (2013) is correct.

Conversely, if the value of  $P(k+1)$  is less than  $P(k)$  then the disturbance must be made in the opposite direction. This is how the Maximum Power Point (MPPT) value can be obtained (Bandri et al., 2019).

### Fuzzy logic-based controller

Schematically, the configuration of the fuzzy controller for a DC/DC converter is given by Figure 5.

Figure 5. Fuzzy Control Scheme for DC/DC Converter

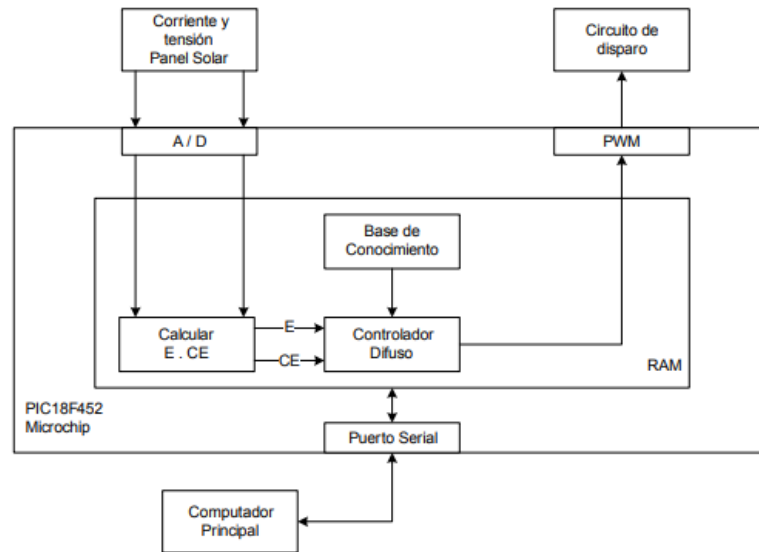

Note. Diffuse control scheme: current and voltage are counted. Taken from González Espinosa (2021). In original language English

In Figure 5 it is observed that both the current and the voltage are counted, and then taken to the A/D channels, this to then obtain the error which is one of the inputs of the fuzzy control, this error is obtained with the following equation:  $E(k)$

$$E(k) = \frac{P(k) - P(k-1)}{V(k) - V(k-1)}$$

Where  $P(k)$  and  $V(k)$  are the power and voltage of the photovoltaic panel, respectively. Therefore, to obtain the maximum power generated it must be zero  $P(k)V(k)E(k)$  (González, 2021).

The remaining input to the fuzzy controller corresponds to the so-called error change, which is determined by making the difference between the current value of the error and its previous value as presented in the following formula:

$$CE(k) = E(k) - E(k-1)$$

The fuzzy controller algorithm is divided into three stages:

1. Fuzzification, where data is transformed to be worked on in a diffuse environment.
2. Inference makes decisions, and defines the rules of the system that are subsequently evaluated to obtain a fuzzy output.
3. Defuzzification is where the output obtained is again transformed into a concrete variable understandable by the rest of the system.

### Simulation and results

The study microgrid located in the Tachina parish of the Esmeraldas Canton, is composed of a 16 kW photovoltaic system and a 30 kW energy storage system. The microgrid can work in a grid-connected manner or isolated in the event of a failure or to save money.

In this case, two models of electricity microgrid are proposed:

- The first model implements an MPPT (Perturb and Observe) algorithm.
- The second model implements a fuzzy controller applied to Maximum Power Point algorithms.

### Model 1. Microgrid with MPPT (Perturb and Observe) Algorithm

In Figure 6, you can see the circuit of the photovoltaic inverter. An MPPT (Perturb and Observe) algorithm was implemented to extract the maximum power from the photovoltaic panel and increase the efficiency of the system, breakers were also added to the output of each subsystem to emulate various scenarios.

Figure 6. Microgrid with MPPT (Perturb and Observe) Algorithm

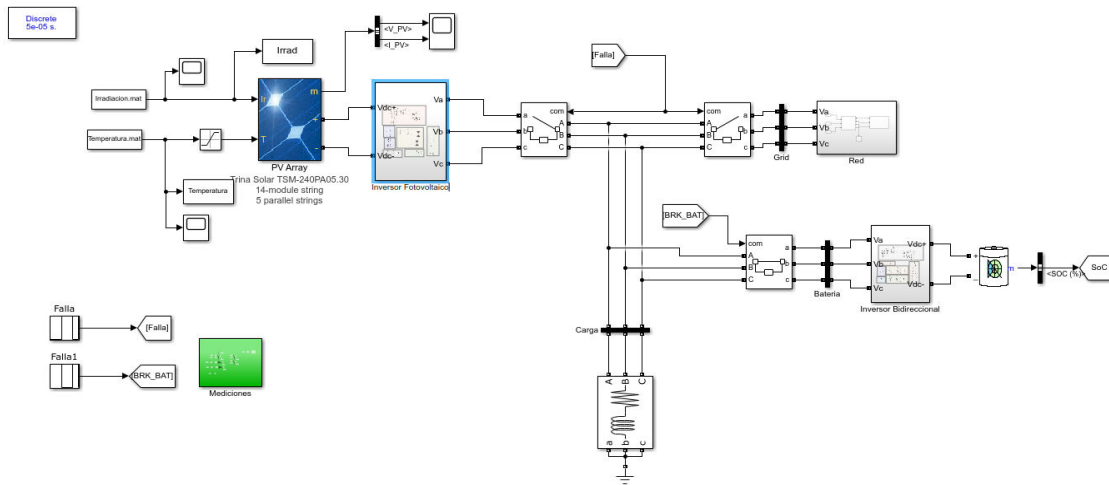

Source: Made with MATLAB/Simulink.

An LC low-pass filter was implemented in the output of the inverter, in order to obtain a sine wave with the lowest possible THD, since due to the transitions of opening and closing the power transistors at high frequencies there are signals at different unwanted frequencies.

Figure 7. Photovoltaic Inverter Circuit.

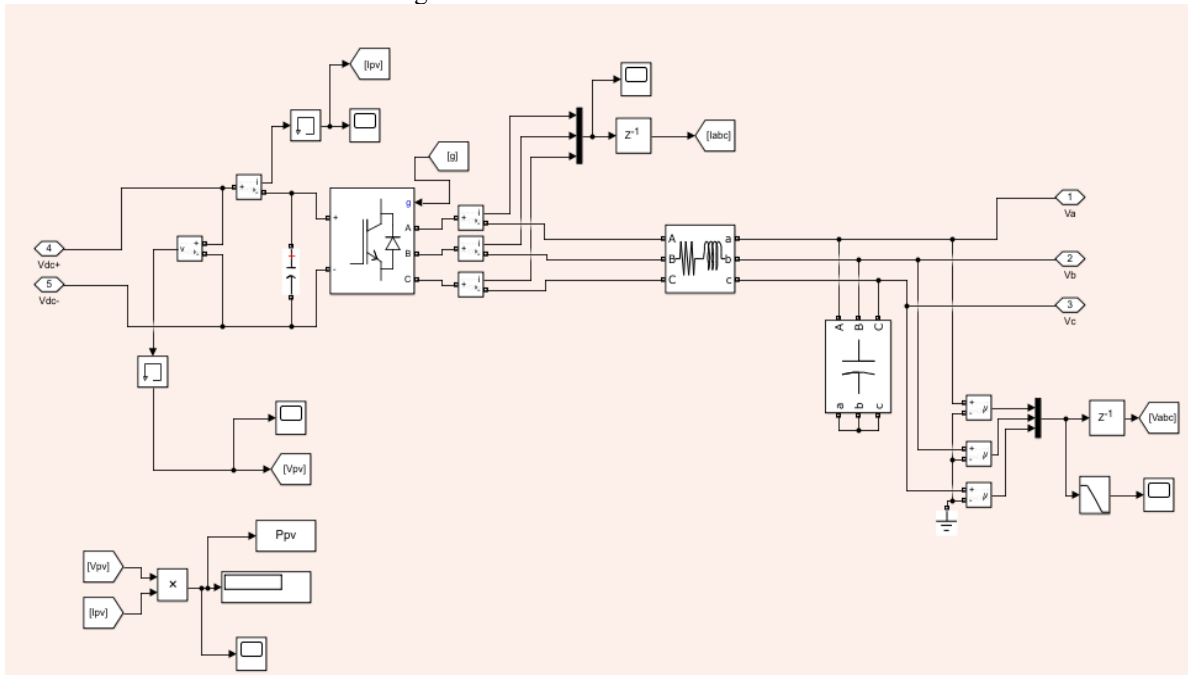

Source: Made with MATLAB/Simulink.

Figure 8 shows the MPPT algorithm implemented in a Simulink function.

Figure 8. MPPT algorithm.

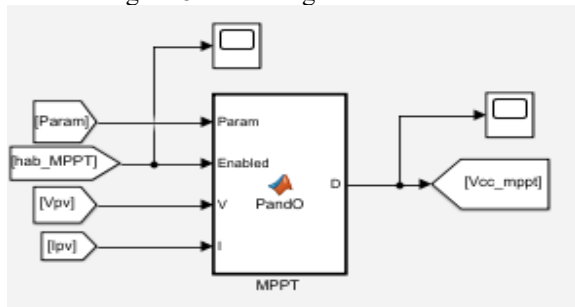

Source: Made with MATLAB/Simulink.

Figure 9 shows the bidirectional inverter, which has the ability to deliver and absorb energy. When the battery's state of charge is below its lower limit value, the battery should no longer be discharged, and when it is above its maximum limit, the battery should not be charged.

It is advisable that these values be respected, precisely to increase the useful life. As in the case of the photovoltaic inverter, an LC low-pass filter is implemented.

Figure 9. Bidirectional inverter.

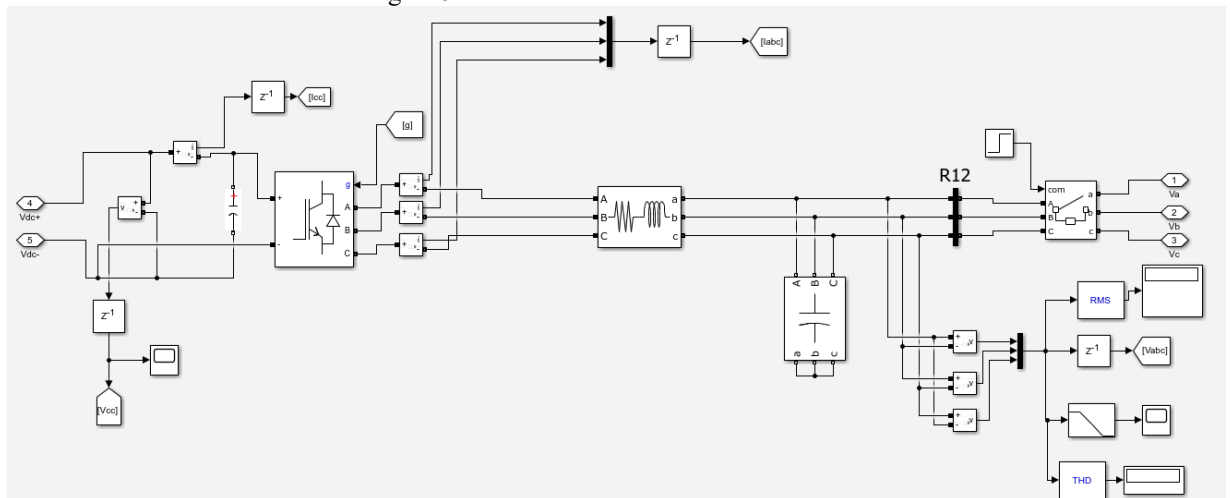

Source: Made with MATLAB/Simulink.

### Model 2. Microgrid with Fuzzy Controller Applied to Maximum Power Point Algorithms

Figure 10 shows below the Micorred model with fuzzy controller applied to maximum power point algorithms

Figure 10. Micorred with Fuzzy Controller Applied to Maximum Power Point Algorithms.

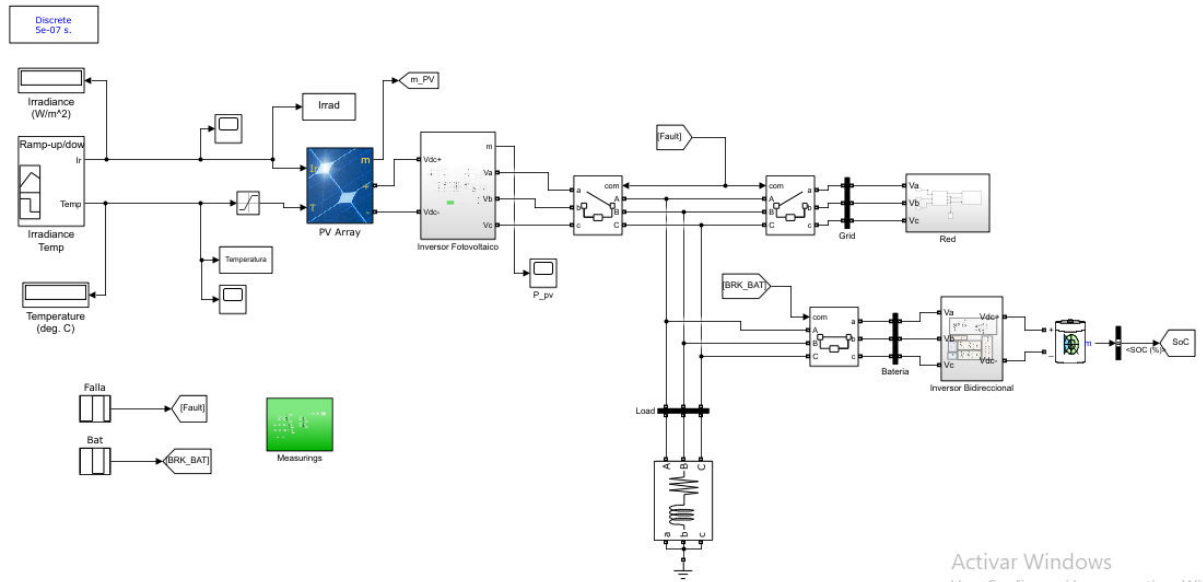

Source: Made with MATLAB/Simulink.

To design a fuzzy controller, it is necessary to analyze the type of inputs and outputs of the system to be controlled. The variables must be established and based on them their respective universe of discourse and functions of belonging must be proposed, so that they better fit the maximum power algorithm.

When defining the variables, the characteristic curves  $P_{vs} V$  and  $I_{vs} V$  of the solar modules are taken as a reference. The inputs selected for the controller are: the error (E) and the error variation (CE), calculated as follows:

$$E(k) = \frac{P(k) - P(k - 1)}{V(k) - V(k - 1)}$$

$$CE(k) = E(k) - E(k - 1)$$

E(k): An error indicating whether the PV panel's operating point is on the right, left, or in the MPP. Analytically it also represents the slope of the curve at time k.

CE(k): The error variation represents which direction the operating point moves.

The output of the diffuse controller (D) is the control signal of the converter and can undergo increases or decreases to regulate the system working in the MPP. The duty cycle can be calculated with the sum of the variation of the duty cycle and the previous value.

$$D(k) = \Delta D(k) + D(k - 1)$$

Based on the design, five linguistic variables are created for each input of the controller, which are: Large Negative (NB), Small Negative (NS), Zero (SE), Small Positive (PS), and Large Positive (PB). Figures 11a, 11b, and 11c show the variables:

Figure 11. Input Variable  $E(k)$ ,  $CE(k)$  and Output Variable  $\Delta_D$

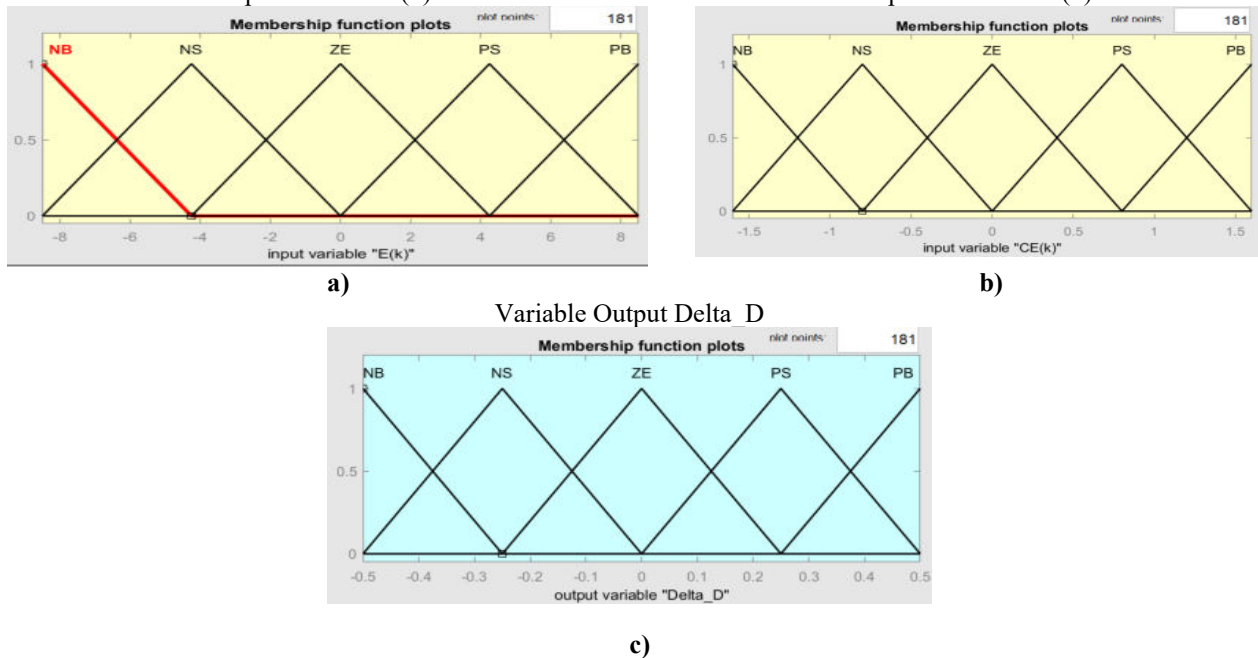

After establishing the functions of belonging and their corresponding universes of discourses, the fuzzy rules are defined. For this system, 25 control rules were established that depend on the number of functions of belonging to inputs and outputs. Figure 12 a shows the rules used themselves, which are "If-Then". The control surface can be generated with the rulers, as can be seen in Figure 12 b. The control surface indicates the behavior of the Fuzzy controller based on the input signals.

Figure 12. Control Rules and Control Surface

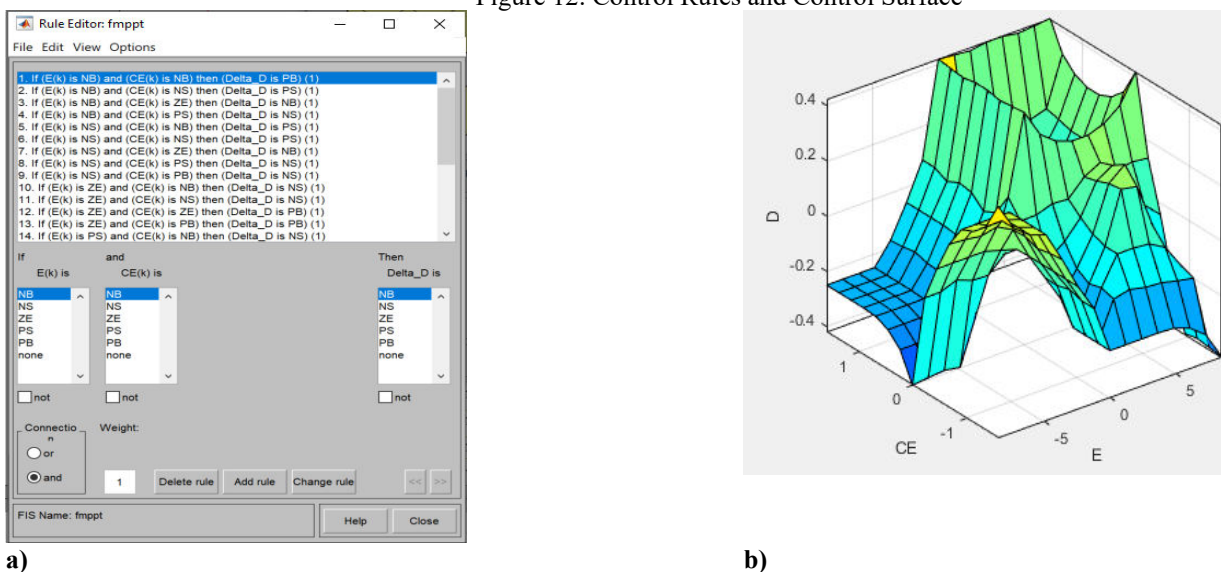

The circuit implemented for the MPPT controller of the Fuzzy logic can be visualized. The first part is the construction of the input variables  $E$  and  $CE$ , the Fuzzy Logic Controller block contains the fuzzy logic. Finally, the duty cycle that will be the control signal of the Boost converter is calculated.

Figure 13. Diagram of the Fuzzy Algorithm Applied to the Tracking of the Maximum Power Point of the Photovoltaic Module

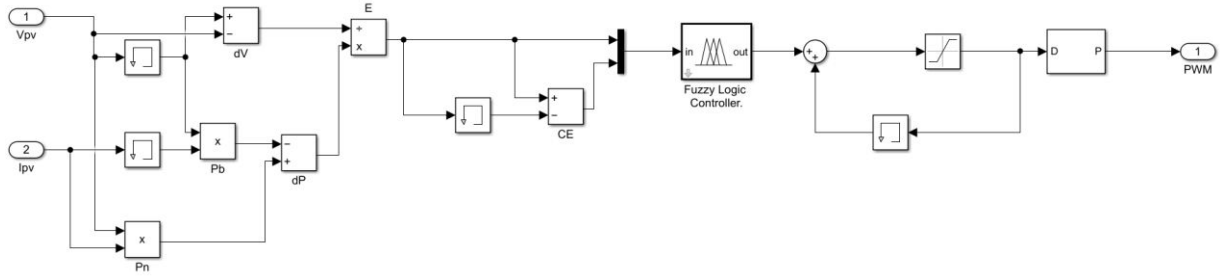

**MATLAB/Simulink Results**

Figure 14 shows the voltage signal of the photovoltaic panel, it can be seen that at the instant  $t=0.015s$  the Fuzzy controller works at its maximum operating point equal to 174.1.

Figure 14. Photovoltaic Panel Voltage Curve

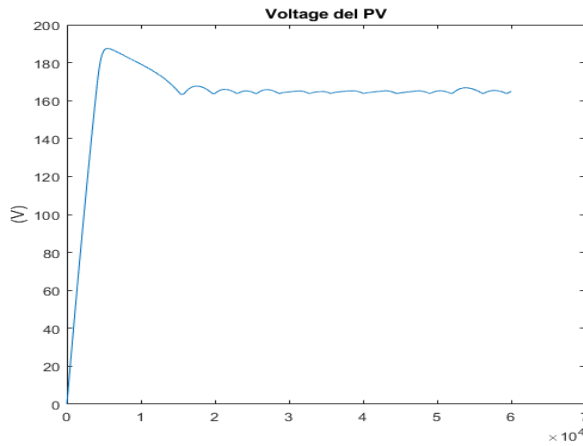

In Figure 15, you can see that at the beginning of the simulation the Fuzzy controller goes past the maximum power point due to the value of the error variation, then the controller causes the voltage to move clockwise until it reaches the MPP.

Figure 15. Characteristic P vs V curve

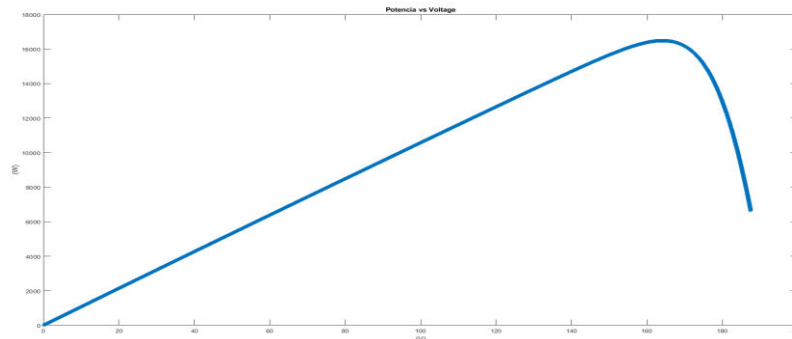

In Figure 15a, the first graph we can see the state of charge of the battery. The SOC indicates the amount of energy, in percentage of charge and discharge of the battery. A battery can operate within a safe operating range in which the voltage signature is nearly linear. The range of the safe operating window can imply potential differences, but the secure SoC is usually set between 20% and 80%.

Beyond certain values, batteries cannot continue to store or deliver energy at risk of degrading or being in unsafe operating conditions.

We can observe that the battery is discharging from zero to four seconds, and more or less in four seconds we can imagine that it is at 20% of its total capacity, then it will not be able to discharge anymore. In this way, it will be necessary to charge the battery, in four seconds it begins to charge the battery again by simulating the behavior of the bidirectional inverter that the energy can go from one side to the other.

The second graph shows that when the current is delivered to the battery, even over discharge, it is positive, while a negative value is obtained in the state of charge.

Figure 15 a. Battery State of Charge. In original language English

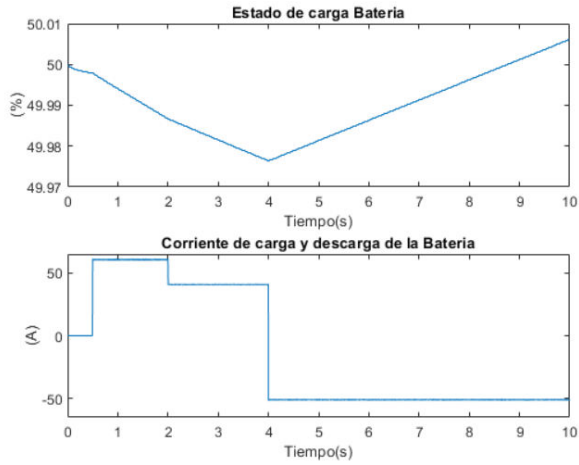

Figure 15 c. Photovoltaic Panel Power. In original language English

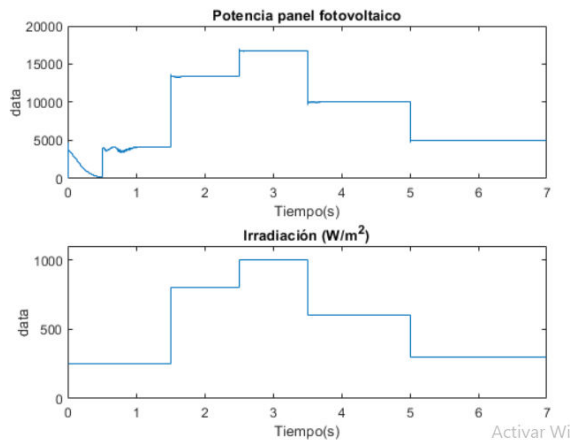

Figure 15 e. THD of Current at Charge. In original language English

Figure 15 b. Voltage and Current of the Charge. In original language English

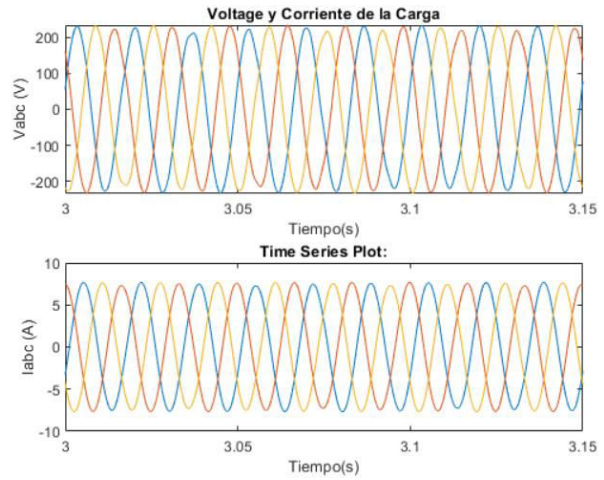

Figure 15 d. Battery Current. In original language English

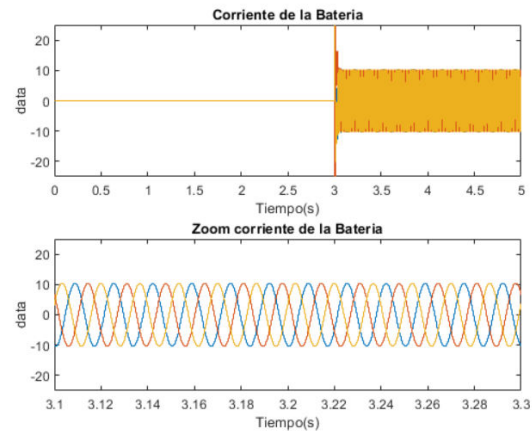

Figure 15 f. Voltage and Irradiation of the Photovoltaic Panel. In original language English

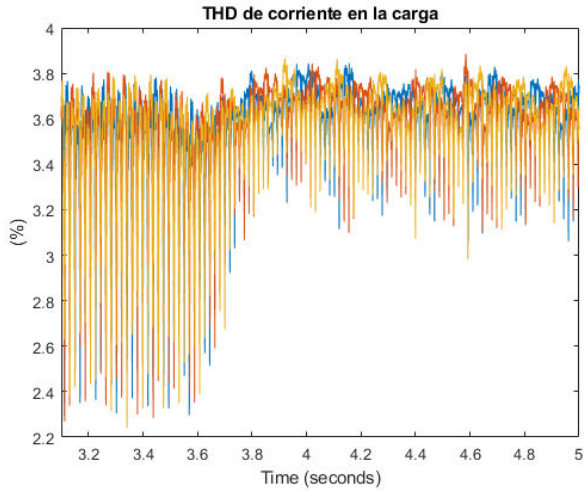

Figure 15 g. Characteristic curves of the Photovoltaic Panel. In original language English

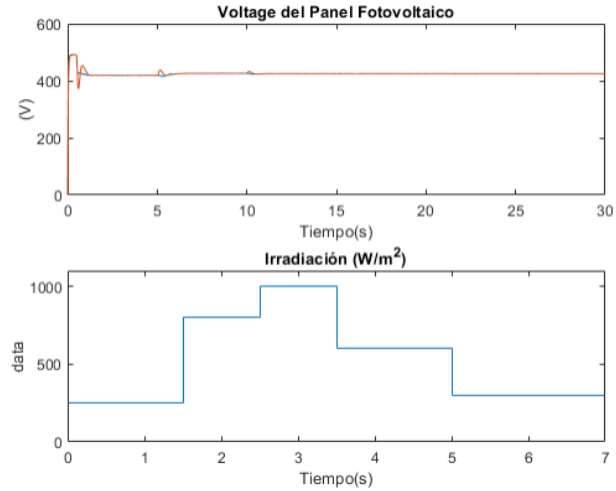
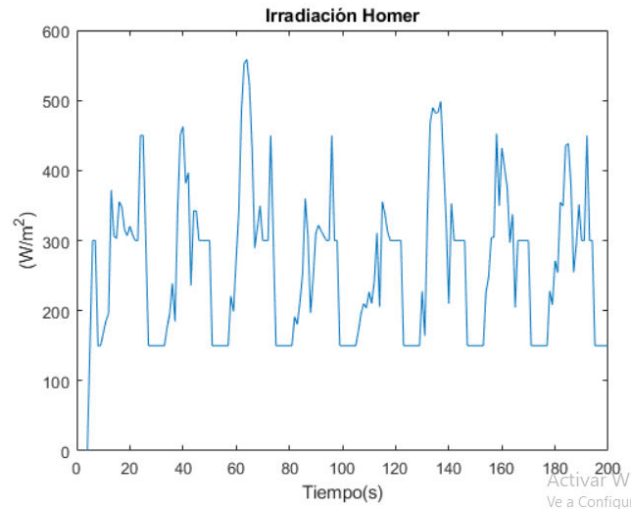
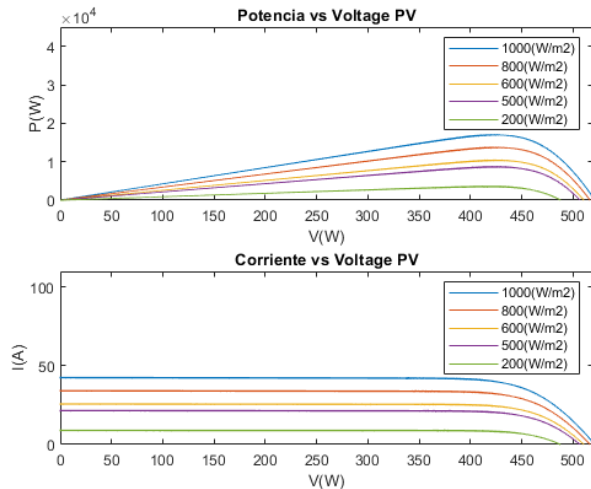

Figure 15 h. Irradiation Data. In original language English



During a period of three seconds, it was possible to verify the delivery of energy by the grid, leading to the global energy supply. This is shown in Figure 15 b, which shows the transmission of the minimum time over the operation of the battery.

Figure 15 c shows the graph of the power of the photovoltaic panel, which at 0.5 the inverter is disconnected because it needs time to synchronize with the grid. At 0.5 it is connected to the inverter and we see that the irradiation in this case is 250W/m<sup>2</sup>, so more or less we have a power of 4000 W/m<sup>2</sup>, since the maximum irradiation power in 1000W/m<sup>2</sup> corresponds to 16 kW. In that sense, in 1.5 seconds let's imagine that we are reaching noon then the irradiation increases and the power that is going to be delivered to the grid also increases, and in 2.5 seconds it happened that we are already at noon at maximum irradiation then we deliver the maximum power.

In Figure 15 d, in the first graph we can see that from zero to three seconds the electrical network is delivering energy, so the battery at that moment is not charged or discharged, that is, the battery is at rest, let's imagine a UPC that when some failure occurs in the network the battery enters to deliver energy.

Figure 15 e shows the current distortion in the load, which is within normal parameters.

Figure 15 f shows below the graphs of the photovoltaic panel voltage and irradiation that vary in different values, we can see that if we vary by 1.5 we transform from 250 W/m<sup>2</sup> to 750 W/m<sup>2</sup>, the photovoltaic panel works at the maximum power point in each variation, that is, it works at its highest efficiency point, where it was validated for different irradiation values to see the behavior of the photovoltaic system.

Figure 15 g, represents the characteristic curves of the photovoltaic panel, where the irradiation was varied and it has that for each irradiation there is a different curve, it can be seen that in the value of 425 W/m<sup>2</sup> is the maximum power point, that the photovoltaic system is working at its maximum point to extract the maximum power.

Figure 15h represents the irradiance data from the Homer software that is plotted in the MATLAB/Simulink software.

### Conclusions

Through the literature review carried out, it has been possible to learn about different solutions for the improvement of the electricity service. These solutions, mostly based on the modernization of electricity distribution networks to smart grids, and which implement technologies that guarantee the continuous supply of electricity to users, can be implemented in the future to improve the quality of the electricity service.

From the evaluation methodology, positive results have been obtained, it can be verified that, through the correct use of the energy resource, it has been determined that solar energy is the most convenient and usable for its use.

The model of the electrical microgrid and its energy management in a case study, proposes an area composed of 25 homes that is located in a climatic area that provides the ideal conditions. For reasons of availability of renewable energy resources, photovoltaic energy is considered as a source of energy supply.

Two microgrid models were proposed in MATLAB/Simulink, where the first implements an MPPT (Perturb and Observe) algorithm that varies in order to stay at the maximum point, and the second adapts a fuzzy controller applied to Maximum Power Point algorithms that is located at the maximum point, allowing 100% work and better use of the energy resource.

In the design of the fuzzy controller, the inputs and outputs of the system were analyzed, variables were established, the respective universe of discourse and belonging functions were proposed, so that they were better adjusted to the maximum power algorithm.

The variables were defined, where the characteristic curves  $P$  vs  $V$  and  $I$  vs  $V$  of the solar modules were taken as a reference, being the inputs to control the error ( $E$ ) and the error variation ( $CE$ ), and the output of the fuzzy controller ( $D$ ) is the converter control signal, the same that underwent increases and decreases to regulate that the system works at its maximum power point.

It is also proposed to seek the sponsorship of institutions specialized in alternative energy issues, large companies and financial entities for the financing of future photovoltaic energy projects within the canton of Esmeraldas in order to promote the energy transition to clean energies with its own resources, together with the fact of promoting environmental sustainability environmental responsibility framed in SDG 7 of the 2030 Agenda on the supply and access of energy for all in line with the responsibility of caring for natural ecosystems.

### Bibliographic References

- Abascal Pelayo, V. M., & Feijoo Ugalde, P. (2009). Implementation of Genetic Algorithms on the parallel development platform CUDA.
- Al Garni, H. Z., Awasthi, A., Ramli, M. A. J. E. c., & management. (2018). Optimal design and analysis of grid-connected photovoltaic under different tracking systems using HOMER. 155, 42-57.
- Aldana, N. L. D. (2016). Coordinated Control and Management of Distributed battery-based energy Storage Systems for Islanded Microgrids.
- Aldona, K., Pawe O. (2017). "Energy audits in industrial processes". Journal of Cleaner Production, vol 142, pp. 3437-3453.
- Andrade, D., Andrés C., Hernández j. "Smart Grid: ICTs and the Modernization of Electric Power Grids-State of the Art," vol. 9, pp. 53–81, 2011.
- Andrade Granja, K. A. (2021). Optimal management system for geographically distributed micro-grids that allow maximizing the sale of energy based on demand response programs. Retrieved from <https://acortar.link/avDrx7>
- Bandri, S., Syofian, A., & Effendi, A. (2019). The application of perturb and observe algorithm to optimized of solar cell output. Paper presented at the Journal of Physics: Conference Series.
- Barragán Escandón, E. A. (2019). Energy self-sufficiency in developing countries in the framework of urban metabolism: Cuenca case, Ecuador. Retrieved from <https://acortar.link/8n9JNj>
- Bhasin, H., & Bhatia, S. J. I. (2011). Application of genetic algorithms in machine learning. 2(5), 2412-2415.
- Buchmann, I. (2001). Batteries in a portable world: a handbook on rechargeable batteries for non-engineers.
- Bordón, C. F., Schenberger, L., Berterame, F., Chezzi, C. M., & Penco, J. J. (2018). Strategy for the Management of a Micro Network. 2018 IEEE 9th Power, Instrum. Meas. Meet. EPIM 2018. Retrieved from <https://acortar.link/jCkuya>
- Castillo-Cagigal, M., Caamaño-Martín, E., Matallanas, E., Masa-Bote, D., Gutiérrez, Á., Monasterio-Huelin, F., & Jiménez-Leube, J. J. S. e. (2011). PV self-consumption optimization with storage and Active DSM for the residential sector. 85(9), 2338-2348.
- ECLAC, N. (2003). Energy and Sustainable Development in Latin America and the Caribbean: Guide for the Formulation of Energy Policies: ECLAC.

- Chen, W., & Wei, P. J. E. P. (2018). *Socially optimal deployment strategy and incentive policy for solar photovoltaic community microgrid: A case of China*. 116, 86-94.
- Contreras, D. I. (2020). *Methodological proposal to size and evaluate, technically and economically, urban micro-networks*. Retrieved from <https://acortar.link/90usNF>
- Cortez, F., Hermamdez M., Martell M. (2018). *Design of an energy management system based on the ISO 50001 standard for the Faculty of Dentistry of the Universidad del Salvador*.
- Cobos, F. J. V. (2020). *Planning with universal access to energy methodology and construction project of electricity grid and alternative energy in rural areas of Cochabamba, Bolivia*. Polytechnic University of Madrid, Retrieved from <https://acortar.link/B4kCag>
- Cruz Saavedra, J. A. D. L. (2020). *Development of a multi-agent decentralized adaptive protection scheme for an electrical Microgrid*. Universidad Nacional de Colombia sede Medellín, Retrieved from <https://n9.cl/ahg38>
- Currie, B., Abbey, C., Ault, G., Ballard, J., Conroy, B., Sims, R., & Williams, C. (2017). *Flexibility is key in New York: New tools and operational solutions for managing distributed energy resources*. *IEEE Power and Energy Magazine*, 15(3), 20-29. doi:10.1109/MPE.2017.2660818
- Chaudhary, G., Lamb, J. J., Burheim, O. S., & Austbø, B. J. E. (2021). Review of Energy Storage and Energy Management System Control Strategies in Microgrids. 14(16), 4929. doi:<https://doi.org/10.3390/en14164929>
- Chen, W., & Wei, P. J. E. P. (2018). *Socially optimal deployment strategy and incentive policy for solar photovoltaic community microgrid: A case of China*. 116, 86-94.
- Delgado, D. J. E. M. C. d. S. E. (2016). *National Energy Balance 2016: Base Year 2015 (p. 118)*.
- De Matos, J. G., e Silva, F. S., & Ribeiro, L. A. d. S. J. I. T. o. I. E. (2014). Power control in ac isolated microgrids with renewable energy sources and energy storage systems. 62(6), 3490-3498.
- Díaz, N. L., Coelho, E. A., Vásquez, J. C., & Guerrero, J. M. (2015). *Stability analysis for isolated ac microgrids based on pv-active generators*. Paper presented at the 2015 IEEE Energy Conversion Congress and Exposition (ECCE).
- Dobakhshari A., Azizi S. and Ranjbar, A. 2011. *Control of Microgrids: Aspects and Prospects*. *International Conference on Networking, Sensing and Control*, pp. 38 – 43.
- Economiques, O. d. c. e. d. d. (2014). *Energy efficiency indicators: Essentials for policy making: OECD Publishing*.
- Farret, F. A., & Simoes, M. G. (2006). *Integration of alternative sources of energy: John Wiley & Sons*.
- Farrokhbadi, M., Cañizares, C. A., Simpson-Porco, J. W., Nasr, E., Fan, L., Mendoza-Araya, P. A., . . . Lagos, D. J. I. T. o. P. S. (2019). Microgrid stability definitions, analysis, and examples. 35(1), 13-29.
- Fossati J. (2011). *Literature review on smart microgrids. Report on Scientific and Technical Dissemination Works, No. 9. ISSN 1510-7450*.
- Franco Mendoza, J. L., & Murillo Anaconda, C. D. (2021). *PID control design for an IoT-tuned spatial motion mechanism*.
- García, F., Hernández, G., & Luna, N. (2011). *OLADE Energy Statistics Manual*.
- García C., Meneses J., Ibarguengoytia P. (2010). *Smart Grid: communications and sensing. VIII International Congress on Innovation and Technological Development, November 24-26, 2010, Cuernavaca, Morelos, Mexico*.
- García, R. H. (2021). *Genetic algorithms in differential equations*.
- Gaviria Cataño, F. A., & Gómez Leal, J. C. (2018). *Optimization methodology for electrical microgrids in non-interconnected areas*. Universidad Autónoma de Occidente.
- Getting Smart. (2008), *IEEE Power & Energy magazine*.
- Gipuzkoa: s.n., (2009). *Centre for Technical Studies and Research of Guipuzkoa. Micro Grid project proposal. Page 2*.
- González Espinosa, R. A. (2021). *Design, Implementation and Evaluation of DC-DC Converter for Photovoltaic Applications*.
- Gómez, V. A., Hernández, C., & Rivas, E. J. I. t. (2018). *Overview, Features and Functionalities of the Smart Grid*. 29(2), 89-102. doi:<http://dx.doi.org/10.4067/S0718-07642018000200089>
- Guamán Sánchez, C. F. (2017). *Design of a microgrid based on renewables to supply electricity to a concession area of the Central South Regional Electric Company*.
- Guanoluisa Pilatásig, I. D. (2018). *Use of genetic algorithms for the optimal location of reclosers in radial distribution networks – application to the Quito Electric Company. Quito, 2018.*,
- Guayanlema, V., Fernández, L., & Arias, K. J. E. R. d. e. d. L. y. e. C. (2017). *Analysis of energy performance indicators in Ecuador*. 1(2), 122-139.
- Hafez, O., & Bhattacharya, K. J. R. E. (2012). Optimal planning and design of a renewable energy based supply system for microgrids. *Acts* 45:7-15.

- Hamidi V., Senior K., & Wilson, R. (2010). *Review of Smart Grid Technology in the Transmission and Distribution Sector, Innovative Smart Grid Technologies Conference Europe (ISGT Europe), IEEE PES*, pp. 1 - 8.
- Hammad A., et al. (2009). *Review of Technologies and Implementation Strategies in the Smart Grid Area. Kan, Power Engineering Conference, AUPEC*, pp. 1-6.
- Hurtado E., Escamilla J. (2015) *Comprehensive energy demand management model. Rev.fac.cienc.econ., Vol. XXIII (2), December 2015, 137-147, DOI: <http://dx.doi.org/10.18359/rfce.1612>. Retrieved from: <http://www.scielo.org.co/pdf/rfce/v23n2/v23n2a10.pdf>*
- IEA. 2011. *Technology Roadmap Smart Grids. International Energy Agency.*
- Jamaica Obregón, J. (2019). *Optimal operation strategies of grid-connected microgrids. Universidad Autónoma de Occidente, Retrieved from <https://n9.cl/edec>*
- Jarrin D. (2017). *Energy management for optimal demand response in smart microgrids. Salesian Polytechnic University, Quito, Ecuador.*
- Katiraei, F., Iravani, R., Hatziargyriou, N., Dimeas, A. J. I. p., & magazine, e. (2008). *Microgrids management. 6(3), 54-65.*
- Keyhani, A. (2016). *Design of smart power grid renewable energy systems: John Wiley & Sons.*
- Khayat, Y., Shafiee, Q., Heydari, R., Naderi, M., Dragičević, T., Simpson-Porco, J. W., . . . Guerrero, J. M. J. I. T. o. P. E. (2019). On the secondary control architectures of AC microgrids: An overview. *35(6), 6482-6500.*
- Lasseter, R. H. J. P. o. t. I. (2011). *Smart distribution: Coupled microgrids. 99(6), 1074-1082.*
- Lee Y., Paredes J., Lee S. (2012). *Smart Energy Grids and their Implementation in Sustainable Cities RG-T2058. Inter-American Development Bank Department of Infrastructure and Environment Energy Division TECHNICAL NOTE # IDB-TN-446.*
- Lee, Y., Paredes, J. R., & Lee, S. H. (2018). *Smart energy grids and their implementation in sustainable cities. Inter-American Development Bank.*
- Luzuriaga Velasco, J. A., & Arcos Avilés, D. G. (2020). *Design and simulation of an energy management strategy for an isolated Microgrid.*
- Marañda, W., & Piotrowicz, M. (2010). *Short-time energy buffering for photovoltaic system. Paper presented at the Proceedings of the 17th International Conference Mixed Design of Integrated Circuits and Systems-MIXDES 2010.*
- Marcos Gestal, R., & Gestal, M. (2010). *Introduction to genetic algorithms and genetic programming: Universidade da Coruña.*
- Márquez, A. C. (2021). *PID control system tuned by Differential Evolution algorithm and Ziegler-Nichols applied to DC engines.*
- Marra, F., & Yang, G. J. S. D., CA, USA: Academic. (2015). *Decentralized energy storage in residential feeders with photovoltaics. 277-294.*
- Marzband, M., Ghazimirsaeid, S. S., Uppal, H., & Fernando, T. (2017). *A real-time evaluation of energy management systems for smart hybrid home Microgrids. Electric Power Systems Research, 143, 624-633. doi:<https://doi.org/10.1016/j.epsr.2016.10.054>*
- Medina, O. (2012). *Smart grids: reality, utopia or future? Argentine Electrotechnical Association. Retrieved from: <https://acortar.link/td2Ob8>*
- Michael G. 2010. *The smart grid and the key technical challenges of research. Symposium on VLSI Technology (VLSIT), pp. 3 - 8.*
- Morales, D. S. J. S. (2010). *Maximum power point tracking algorithms for photovoltaic applications. 411(80), 82.*
- Moreira, C. L., Lopes, J. P. J. I. A., & Computing, S. (2010). *Microgrids operation and control under emergency conditions. 16(2), 255-272.*
- Mullo, A., Javier, V., Jiménez, M., Pilatasig, M., & Iturralde, H. (2017). *Analysis of the incidence of grounding with high resistivity against atmospheric discharges in the sub—Transmission line of 69KV San Rafael—Mulalo. Paper presented at the 2017 CHILEAN Conference on Electrical, Electronics Engineering, Information and Communication Technologies (CHILECON).*
- Muñoz-Vizhñay, J. P., Rojas-Moncayo, M. V., & Barreto-Calle, C. R. (2018). *Incentive for distributed generation in Ecuador. Ingenius. Journal of Science and Technology, (19), 60-68.*
- Nunes, P., Farias, T., & Brito, M. C. J. E. (2015). *Enabling solar electricity with electric vehicles smart charging. 87:10-20. DOI:<https://doi.org/10.1016/j.energy.2015.04.044>*
- Nick, M., Cherkaoui, R., & Paolone, M. (2017). *Optimal planning of distributed energy storage systems in active distribution networks embedding grid reconfiguration. IEEE Transactions on Power Systems, 33(2), 1577-1590. Retrieved from <https://ieeexplore.ieee.org/abstract/document/8000386>*
- Parejas, M. C. S. (2018). *Relations between the institutionality of the global and regional space in the field of energy. ENERLAC. Journal of Energy of Latin America and the Caribbean, 2(1), 72-90.*

- Perez, R. J. H. p. (1993). Lead-acid battery state of charge vs. voltage. 36:66-69.
- Pribnow Manríquez, S. C. (2017). *Technical-economic analysis for the implementation of electricity microgrids in Chile*.
- Piccolo A., Mokryani G. & Cecati C. (2010). *An overview of the concept of the smart grid. 36th Annual Conference on IEEE Industrial Electronics Society*, pp. 3322- 3327.
- Prinanda, C., & Sulistyowati, R. J. S. T. I. S. (2015). Análisis dan Simulasi Metode Hill Climbing Untuk Mximum Power Point Tracker (MPPT) pada Photovoltaic Statis.
- Qin, L., & Lu, X. J. P. P. (2012). Matlab/Simulink-based research on maximum power point tracking of photovoltaic generation. 24:10-18.
- Quiroz Rodríguez, A. F. (2019). Optimal placement of storage systems to maximize continuity of service in a microgrid.
- Ramírez Loaiza, D. A. (2020). Tertiary control in microgrids: an optimal power flow approach based on convex optimization and Wirtinger calculus.
- Ravindran, V., & Sutaria, J. (2016). *Implementation in arm microcontroller to maximize the power output of solar panel using Hill Climbing Algorithm*. Paper presented at the 2016 International Conference on Electrical, Electronics, and Optimization Techniques (ICEEOT).
- Romo Fernández, L. M. (2016). *Analysis of scientific production in renewable energies*. Retrieved from <https://acortar.link/3pk1s4>
- Rosales Manzo, D. E. (2020). *Takagi-Sugeno diffuse system for humidity and temperature monitoring of banana crops*.
- Ruiz Villadiego, M. A. (2019). *Case analysis in projects with a social focus: micro-networks and the community. Universidad Nacional de Colombia*, Retrieved from <https://n9.cl/46vi4>
- Sánchez Silvera, A. (2020). *Energy management based on Multi-Agent systems for Micro-Grids in island mode*. Retrieved from: <https://acortar.link/wJhJGx>
- Sudati, L. U. (2018). *Ferramenta híbrida para otimização da produção seriada usando o controlador fuzzy*.
- Savina, N., Myasoedov, Y., & Myasoedova, L. (2018). *Influence of quality of the electric energy on reliability of electrical supply systems. Paper presented at the 2018 International Multi-Conference on Industrial Engineering and Modern Technologies (FarEastCon)*.
- Sekhar, P. C., Deshpande, R., & Sankar, V. (2016). *Evaluation and improvement of reliability indices of electrical power distribution system. Paper presented at the 2016 National Power Systems Conference (NPSC)*.
- Serrano González-Peramato, J. I. (2020). *Relief of congestion in distribution networks with electric vehicles with V2G capacity*. Retrieved from <https://repositorio.comillas.edu/xmlui/handle/11531/46491>
- Sevilla, A. G. P., & Fernández, F. O. A. (2013). Evolution of electricity grids towards Smart Grid in countries of the Andean Region. *Journal of Engineering Education*, 8(15), 48-61.
- Silva, R. C. (2018). Estudo sobre topologias de algoritmos genéticos paralelos com aplicação em minimização de funções numéricas irrestritas.
- Shan, X. (2021). *Development and simulation using Simulink Power Systems of an energy management system for a 3.3 kW isolated photovoltaic installation with battery storage*. Universitat Politècnica de València, Retrieved from <https://riunet.upv.es/handle/10251/170906>
- Schuler, R. E. (2018). The Smart Grid. The Bridge, 42–50.
- Storage, E. (2008). IEEE Guide for Optimizing the Performance and Life of Lead-Acid Batteries in Remote Hybrid Power Systems.
- Tolón Martín, T. I. (2013). Operation and management of urban energy microgrids in an environment of energy and environmental sustainability [Master'sThesis]. Universitat Politècnica de Catalunya.
- Venegas J., Castaño J. (2012). Energy management models: review of some international experiences and perspectives for Colombia. TRILOGÍA Magazine No. 6 / ISSN 2145-4426 / April – October / 2012 / pp. 77 – 92, Retrieved from: <file:///E:/MI%20DATA/Downloads/SSRN-id3528719.pdf>
- Wijaya, H. J. b.-T. (2019). Optimization of Application of Genetic Algorithm Using C4. 5 Method to Predict Breast Cancer Disease. 2(1), 1-10.
- Yatimi, H., & Aroudam, E. (2015). *Modeling and simulation of a stand-alone photovoltaic system*. Paper presented at the Xeme Conférence Internationale: Conception et Production Intégrées.
- Ziebell, A. C., & Singh, V. K. J. P. o. t. I. o. C. E.-E. (2018). Energy indicator in sustainable urban energy metabolism and challenges. 171(1), 26-31. DOI:<https://doi.org/10.1680/jener.17.00010>
- Zorita, A. (2017). Description and infrastructure of a microgrid for a residential environment. University of Valladolid, School of Industrial Engineering. Retrieved from: <https://core.ac.uk/download/pdf/211107164.pdf>

David Ricardo Macas-Mendoza, Ismael Elías Erazo-Velasco, Junior Manfredo Rojas-Rosado, José Vicencio Bautista-Sánchez, Byron Emilio Blandon-Matamba, Roberto Iván Rodríguez-Jijón

Zúñiga G., Ornelas F. & Rico J. (2013). Forecast-based optimization for a smart microgrid, Baja California – Mexico. Universidad Michoacana de San Nicolás de Hidalgo